





SHM Flowmeter

Analog/Mechanical Cold 50°C and Hotwater 90°C Waste/Sewage Meter
 Size : DN50-DN300 (50mm-300mm ; 2" - 12")

SHM – Sewage Hi-flo Meters - Analog/Mechanical Flowmeter for Waste/Sewage Water is an epoxy coated cast iron, it has great flow rate measure and resistant from many light chemicals and corrosion. It can be used for a remote reading transmission system as equipped with built-in sensor (optional) and with Data Logger, it can record for last six months logs.

				
Flowmeter Cold and Hotwater Mechanical/Analog/Pulse - Sewage/Waste Water Type		Stainless Steel 304 and 316 Type	High Quality Magnetic Vacuum Glass Register	Data Logger For Pulse Type

Features:

- Easy Installation and Maintenance
- Dry Dial, Magnetic Drive
- High Bypass and Very Low Head Loss
- Glass Vacuum Sealed Register -Free from Condensation and clear for long term
- Working Temperature 0.1°C - 50°C for Cold and 0.1°C - 90°C for Hotwater
- Max Pressure: 16 Bar
- Maximum Error : +/- 2%
- Selected High Quality Materials
- Iso 4064
- Warranty 2 Year

Applications:

- Sewage Treatment Plant (STP); i.e: Hospital, Hotel, Industrial, Mall, Residential, Palm Oil Industrial, etc
- Raw Water, Sludge Water and many others
- Inlet and Outlet Water Treatment
- Best suited for pump system and high flowrate
- Many more applications

Technical Specifications :

Size			Max Flow Qmax	Continues Flow Qn	Transitional Flow Qt	Min Flow Qmin
DN	Inch	MM				
			M ³ /Hour			
DN50	2"	50	30	15	3	0.45
DN65	2.5"	65	50	25	5	0.75
DN80	3"	80	80	40	8	1.2
DN100	4"	100	120	60	12	1.8
DN125	5"	125	200	100	20	3
DN150	6"	150	300	150	30	4.5
DN200	8"	200	500	250	50	7.5
DN250	10"	250	800	400	80	12
DN300	12"	300	1200	600	120	18

Dimensions:

Size	L Length	H High	Connection Flange		Weight
MM			D1 Outside Diameter	D2 Bolt Inner Diameter	Kgs
DN50	200	272	165	125	10
DN65	200	274	185	145	11
DN80	225	281	200	160	16
DN100	250	291	220	180	17
DN125	250	312	250	210	21
DN150	300	341	285	240	30
DN200	350	384	340	295	41
DN250	450	435	405	350	66
DN300	500	486	445	400	100

Drawing:

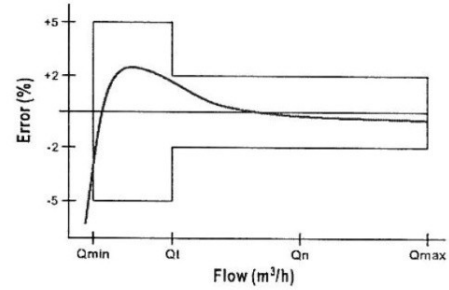
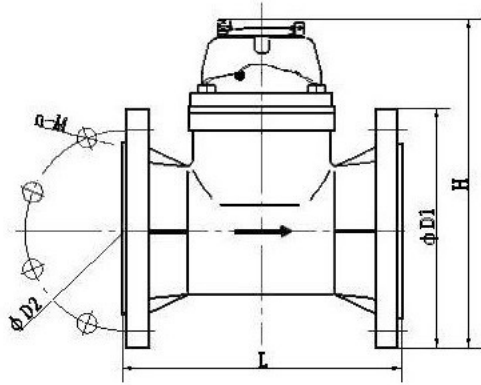

Q_{max} = maximum peak flow
 Q_n = continuous flow
 Q_t = transitional flow
 Q_{min} = minimum flow

Pressure Loss Curve

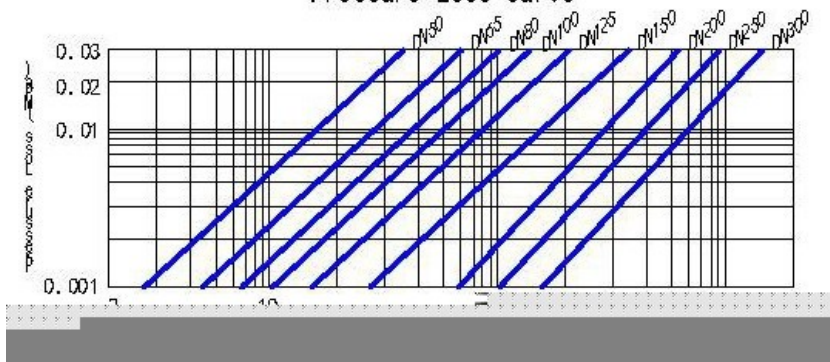

DN50



DN80

